

37ª EDIÇÃO

BAJA PORTALEGRE 2023
500

AUTOMÓVEL CLUB DE PORTUGAL

PROMOÇÃO BAJA & HOBBY
MAPAS
ROAD BOOK LIGAÇÕES
(COMPETIÇÃO)
ROAD BOOK ASSISTÊNCIA
PLANO DE ABASTECIMENTO
OUTROS

26 A 28 OUTUBRO

2023

TAÇA DO MUNDO FIA DE BAJAS • CAMPEONATO DE PORTUGAL DE TODO O TERRENO FPAK
CLASSIC TT • CAMPEONATO NACIONAL DE TODO O TERRENO OPEN FMP • MINI BAJA

BAJAPORTALEGRE500.COM



Nos circuitos do dia a dia, a bp compensa.

Quando está em prova, o Miguel sabe quantas voltas tem de dar. No dia a dia, quem decide o número de voltas é a sua filha. Às vezes adormece logo na primeira, outras vezes, são precisas muitas mais. Mas em todas, o Miguel sabe que a bp compensa. Compensa pela poupança com os cartões de fidelização da bp e compensa pelos quilómetros extra*, obtidos através do uso de combustíveis bp Ultimate com tecnologia ACTIVE. Nos circuitos do dia a dia, a bp compensa e o Miguel aproveita.

O melhor, todos os dias



*Gasóleo bp Ultimate com tecnologia ACTIVE, garante até 56 km extra por depósito. Testado em comparação com combustíveis em conformidade com as especificações definidas pela legislação em vigor. Os benefícios anunciados verificam-se em utilizações continuadas e podem variar de acordo com o estado do veículo, estilo de condução ou outros fatores. Saiba mais em bp.pt

37ª EDIÇÃO

BAJA PORTALEGRE 2023
500

AUTOMÓVEL CLUB DE PORTUGAL



CERIMONIAL START
CERIMÓNIA DE PARTIDA

26-10-2023



Layout
Service Park 2023
V2 07.09.2023

- 1- Entrada principal veículos e peões / main entrance and pedestrian entrance
- 2- Entrada de veículos de competição / entrance competitors only / saída-exit
- 3- Entrada exclusiva a peões / entrance for pedestrians only

P Reboques
Trailers

P Media
Organização /
Organiser



Para / To
 Portalegre
 Gasolinheiras / Gas stations
 Cerimónia de Partida / Ceremonial Start
 SS3 Auto
 SS3 Moto / Quad / SSV
 SS2 Moto / Quad / SSV (Hobby)

- a** TC CS1; TC 2D; TC 3D (só / only auto); TC 4B **e** TC 3C (só / only Auto)
- b** TC 0; TC 2E; TC 3E
- c** TC 2B; TC 3B **c1** TC 2Aa ; TC 3Aa
- d** TC 2C (só / only Auto)
- f** TC V1
- g** TC V2
- h** TC V3

Para / To
 Arnonches
 Espanha / Spain
 Gasolinheiras / Gas stations
 Partida / Start
 SS 1 & SS2 (Auto / Moto)

De / From
 Chegada / Arrival
 SS 1 (Promoção Baja & Hobby)
 SS2 Moto & Auto / Cars
 SS3 & SS4 Auto / Cars
 SS3 Moto / Bike

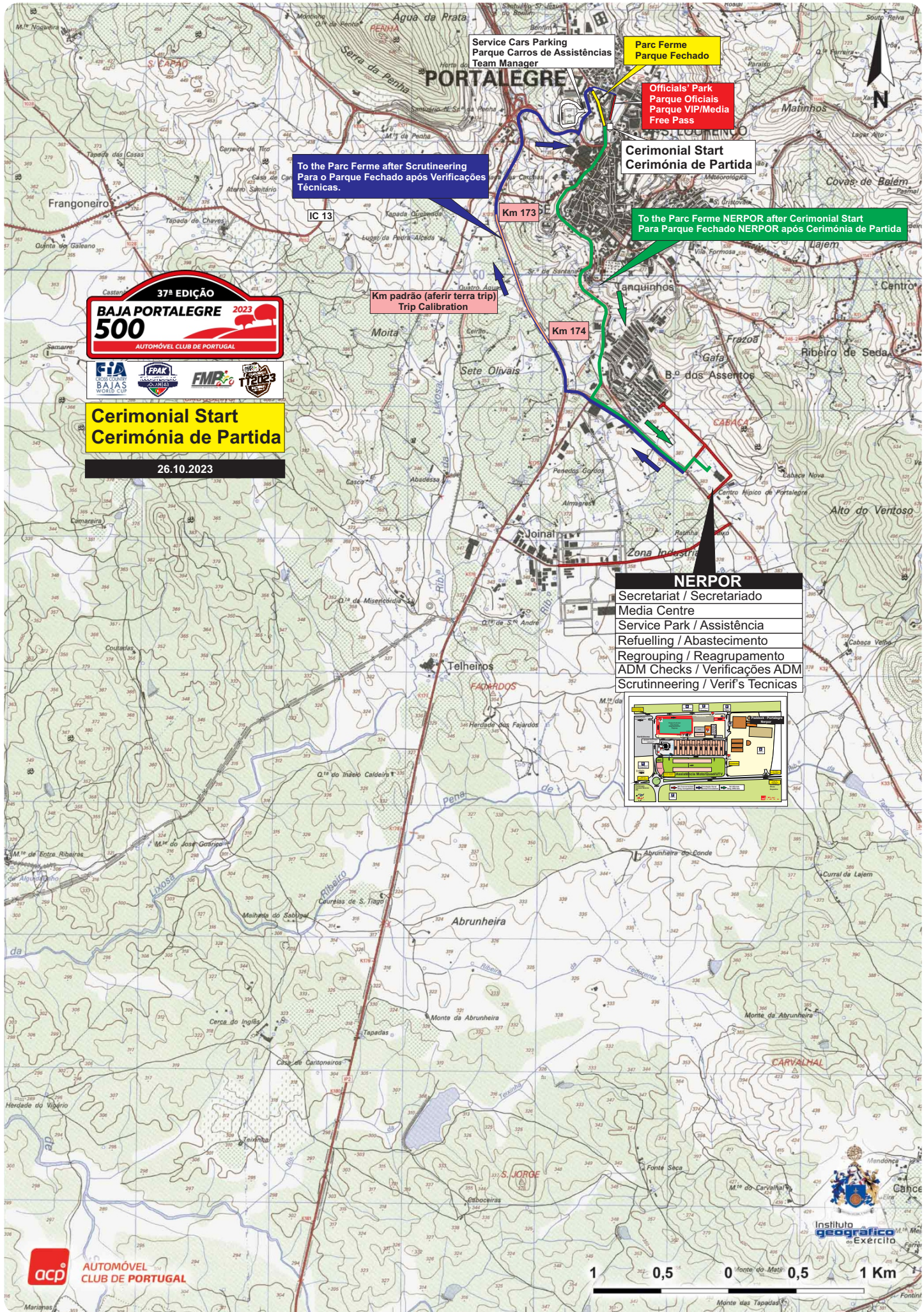

Service Cars Parking
Parque Carros de Assistências
Team Manager

Parc Ferme
Parque Fechado

Officials' Park
Parque VIP/Media
Free Pass

Cerimonial Start
Cerimónia de Partida

To the Parc Ferme after Scrutinering
Para o Parque Fechado após Verificações
Técnicas.

To the Parc Ferme NERPOR after Cerimonial Start
Para Parque Fechado NERPOR após Cerimónia de Partida

Km padrão (aferir terra trip)
Trip Calibration

Km 174

37ª EDIÇÃO
BAJA PORTALEGRE 2023
500
AUTOMÓVEL CLUB DE PORTUGAL



Cerimonial Start
Cerimónia de Partida

26.10.2023

NERPOR

Secretariat / Secretariado
Media Centre
Service Park / Assistência
Refuelling / Abastecimento
Regrouping / Reagrupamento
ADM Checks / Verificações ADM
Scrutinering / Verif's Tecnicas

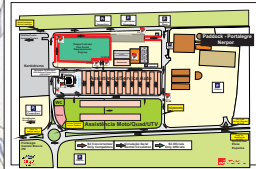



**Cerimonial Start
Cerimónia de Partida**
26.10.2023



2006

Data das imagens: 3/7/2015 39° 17.860'N 7° 25.811'O elev 460 m altitude de visualização 1.20 km

Google earth

37ª EDIÇÃO

BAJA PORTALEGRE 2023

500

AUTOMÓVEL CLUB DE PORTUGAL



ETAPA 1 / STAGE 1

27-10-2023

Promo Baja & Hobby - Moto / Quad / SSV - Refuellings in Liaisons (commercial filling stations) / Postos de Abastecimento Públicos nas ligações / ZA and GAS

Leg 1 / Etapa 1	Km R.B	Location / Localização	Provider / Fornecedor	Fuel Available / Combustível Disponível
Section 1 / Secção 1	0	Nerpor / Service Parck		
Refuelling Liaison	0,76	Zona Industrial de Portalegre	Prio	95 octane Petrol, standart Diesel
Refuelling Liaison	1,31	Zona Industrial de Portalegre	Repsol	All Fuel Available
TC / CH QS1	7,03	Herdade das Coutadas		
Start QS1		Herdade das Coutadas		
Arrival QS1	3,7	Herdade das Coutadas		
Refuelling Liaison	5,62	Zona Industrial de Portalegre	Repsol	All Fuel Available
Refuelling Liaison	6,2	Zona Industrial de Portalegre	Prio	95 octane Petrol, standart Diesel
Service	6,71	Nerpor / Service Parck		
Refuelling Liaison	0,87	Portalegre	Galp, Cepsa, BP	All Fuel Available
Arrival Leg 1	0,87	Nerpor / Service Parck		

Leg 2 / Etapa 2	Km R.B	Location / Localização	Provider / Fornecedor	Fuel Available / Combustível Disponível
Section 2 / Secção 2	0	Nerpor / Service Parck		
Refuelling Liaison	0,87	Portalegre	Galp, Cepsa, BP	All Fuel Available
Refuelling by the Team	36,3	Gáfete	JVC (BP)	Standart diesel, Premium diesel, Petrol 95 standart
TC / CH SS2	36,9	Gáfete		
Start SS2	0	Gáfete		
GAS 1	70	Concavada		
GAS 4	126	Torre das Vargens		
Arrival SS2	190	Coutadas / Portalegre		
Refuelling Liaison	4,82	Zona Industrial de Portalegre	Repsol	All Fuel Available
Refuelling Liaison	5,4	Zona Industrial de Portalegre	Prio	95 octane Petrol, standart Diesel
Arrival Leg2	5,99	Nerpor		

Fuel Available in Portugal:

Petrol 95 octanes standart
Petrol 95 octanes premium
Petrol 98 octanes
Standart diesel
Premium diesel

Cerimónia de Partida							Quinta Feira, 26 de Outubro	
<i>Nascer do Sol - 07:59</i>					<i>Por do Sol - 18:36</i>			
CH	LOCALIZAÇÃO	SS km	Ligação km	Total km	Tempo	1ª Moto		
V4	Parque Fechado IN (Jardim do Tarro)					*		
CS0	Cerimónia de Partida						19:00	
CS1	Nerpor		3,67	3,67	00:30	*	19:30	
totais		0,00	3,67	3,67				

ETAPA 1							Sexta Feira, 27 outubro	
<i>Nascer do Sol - 08:00</i>					<i>Por do Sol - 18:35</i>			
CH	LOCALIZAÇÃO	SS km	Ligação km	Total km	Tempo	1ª Moto		
0	PARTIDA 1ª Secção / 1ª Etapa						07:25	
km 0,76/1,31 - Possível Abastecimento (postos públicos indicados no road book)								
1	CH Partida PRÓLOGO		7,03	7,03	00:20		07:45	
SS1	PRÓLOGO	3,71					07:50	
1A	PRÓLOGO STOP (Tempo Máximo - 30m)			3,71	-		07:55	
km 1,5 - Possível Abastecimento (postos públicos indicados no road book)								
1B	Service Nerpor IN		6,71	6,71	00:30	*	08:25	
SERVICE A (NERPOR)		3,71	13,74	3,71	03:00			
1C	CHEGADA 1ª Secção / 1ª Etapa Nerpor				03:00	*	11:25	
1ª Etapa totais		3,71	13,74	17,45				

ETAPA 2							Sábado, 28 outubro	
<i>Nascer do Sol - 08:01</i>					<i>Por do Sol - 18:33</i>			
CH	LOCALIZAÇÃO	SS km	Ligação km	Total km	Tempo	1ª Moto		
1D	PARTIDA 2ª Secção / 2ª Etapa						06:30	
km 0,54/0,87/35,38 - Possível Abastecimento (postos públicos indicados no road book)								
2	CH Partida SS2		38,92	38,92	01:15		07:45	
SS2	SS2	190,00					07:50	
2A	SS2 STOP (Tempo Máximo 4h35m)			190,00	-		10:50	
km 6,20 - Possível Abastecimento (postos públicos indicados no road book)								
2B	CHEGADA 2ª Secção / 2ª Etapa Nerpor		5,99	5,99	00:30	*	11:20	
2ª Etapa totais		190,00	44,91	234,91				

TOTAIS				
	SS	Ligação	Total	% SS
1ª Etapa - SS1 / SS2	3,71	13,74	17,45	21,3%
2ª Etapa - SS4 / SS3	190,00	44,91	234,91	80,9%
Total	193,71	58,65	252,36	76,8%

* Tempo Máximo, entrada por avanço autorizada

37ª EDIÇÃO

BAJA PORTALEGRE 2023
500

AUTOMÓVEL CLUB DE PORTUGAL



ETAPA 2 / STAGE 2

28-10-2023

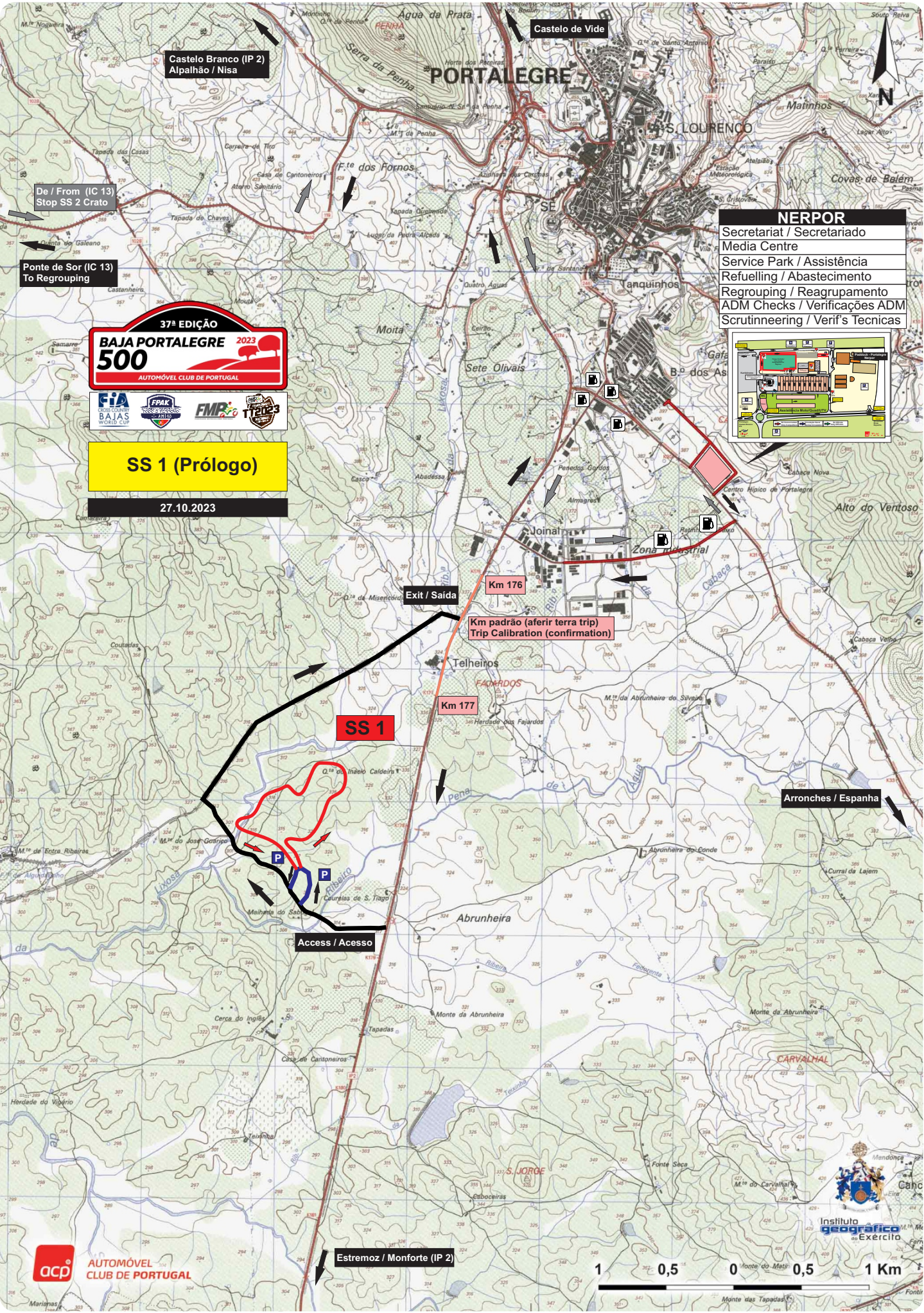

37ª EDIÇÃO
BAJA PORTALEGRE 2023
500
 AUTOMÓVEL CLUB DE PORTUGAL



SS 1 (Prólogo)
27.10.2023

NERPOR	
Secretariat / Secretariado	
Media Centre	
Service Park / Assistência	
Refuelling / Abastecimento	
Regrouping / Reagrupamento	
ADM Checks / Verificações ADM	
Scrutinneering / Verif's Técnicas	

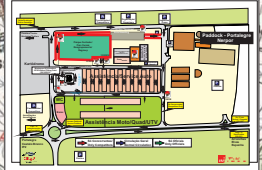

Exit / Saída
Km 176
Km padrão (aférir terra trip)
Trip Calibration (confirmation)

SS 1

Access / Acesso

Arronches / Espanha

Estremoz / Monforte (IP 2)

acp AUTOMÓVEL CLUB DE PORTUGAL





Prólogo / SS1

27.10.2023



Saída/Exit
Para / To NERPOR/Portalegre
Para / To Ponte de Sor
Reagrupamento / Regrouping

← NORMAL CIRCULATION

← CONCORRENTES / COMPETITORS

Acesso / Access
De / From Portalegre



Gáfete - Start / Partida
N 39° 23.495' / W 7° 40.172'

Gáfete
Portalegre (Ip2)
GAS 1 (moto)

Parking:
Free Pass
ORG
Medida

M533



M1021

Vale do Peso
(estação)

400 m

37ª EDIÇÃO
BAJA PORTALEGRE 2023
AUTOMÓVEL CLUB DE PORTUGAL

28.10.2023

Start / Partida:
SS 2 Promoção & Hobby
SS 3 Moto / Quad / SSV
SS 4 Auto



Google Earth

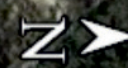

Herdade das Coutadas - Portalegre

N 39° 14.751' / W 7° 27.499'

Arrival - Chegada:
Promo Baja & Hobby
Mini Baja
SS 4 Auto



Arrival / Chegada:
Promo Baja & Hobby
Mini Baja
SS 3 Bike / Quad / SSV
SS 3 & 4 Car / Auto

28.10.2023

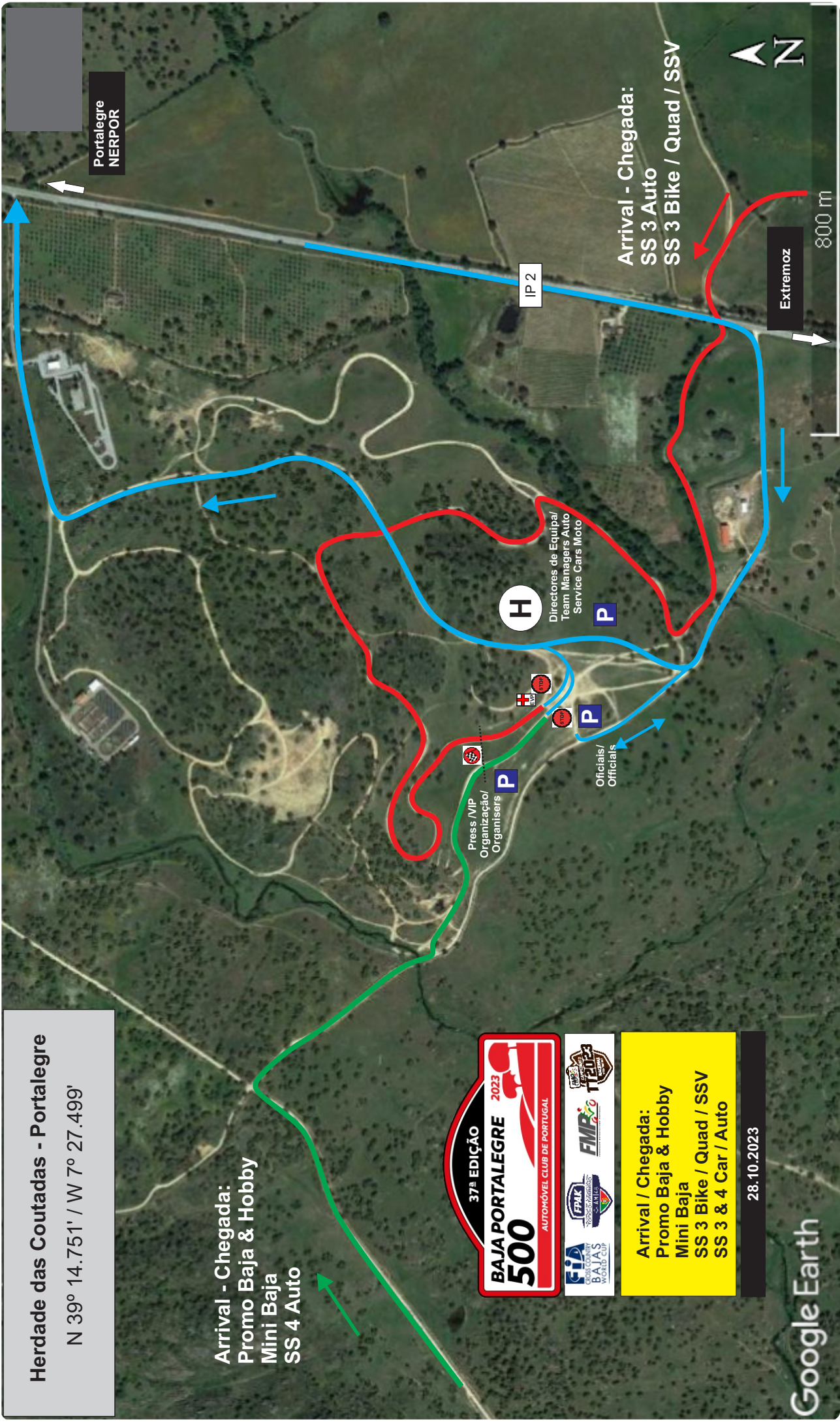

37ª EDIÇÃO

BAJA PORTALEGRE 2023
500

AUTOMÓVEL CLUB DE PORTUGAL







ROAD BOOK
DESENHOS GAS E ZA
27/28-10-2023

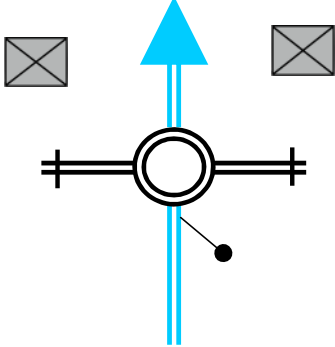
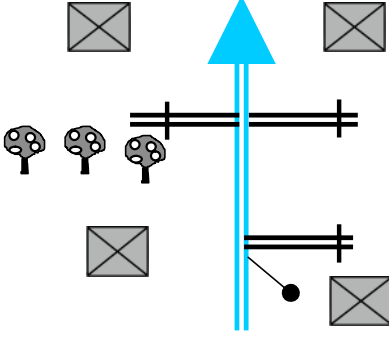
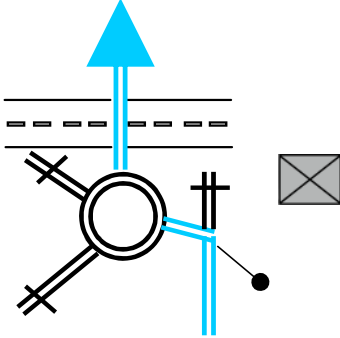
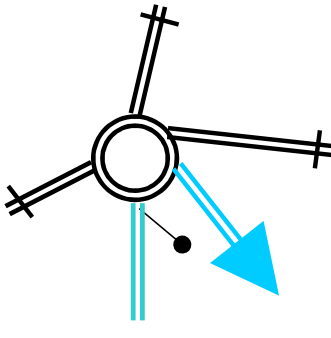
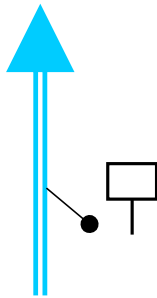

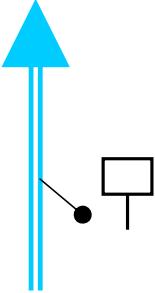
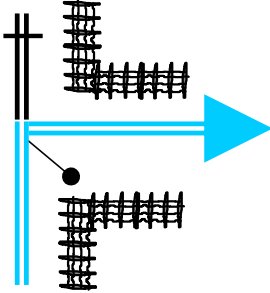
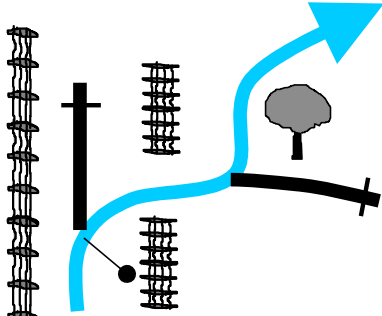

1	NERPOR - PROLOGUE	7,03 km
<p>0,00</p> <p>0,00</p>		
<p>0,76</p> <p>0,76</p>		<p>Zona Industrial</p> <p>→</p> <p>D 95</p> <p>2</p>
<p>1,07</p> <p>0,31 ↓</p>		<p>3</p>
<p>1,31</p> <p>0,24</p>		<p>ON THE RIGHT CAR WASH SELF SERVICE</p> <p>À DIREITA ESTAÇÃO DE LAVAGEM AUTO</p> <p>4</p>

NEXT 0,34

2	NERPOR - PROLOGUE	5,38 km
1,65		5
0,34		
2,14		6
0,49		
2,56		<p>Évora Monforte Escola Superior</p> <p>→</p>
0,42		7
2,91		<p>Évora Monforte</p> <p>→</p>
0,35		8
3,45		<p><u>IP2 KM 176</u></p> <p>TRIP CALIBRATION</p> <p>MEDIDA PADRÃO</p>
0,54		9

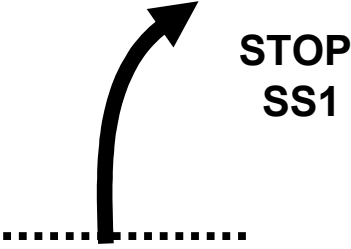
NEXT 1,00

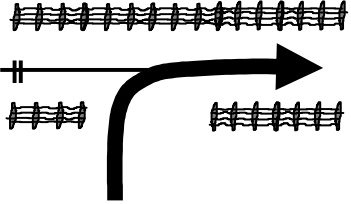
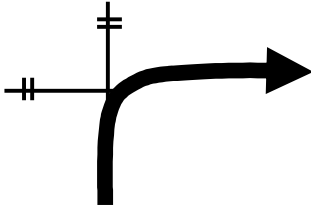
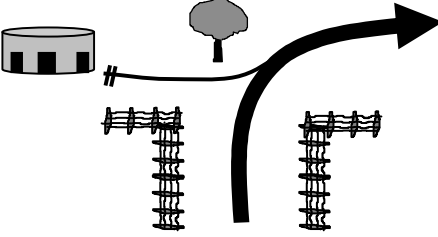
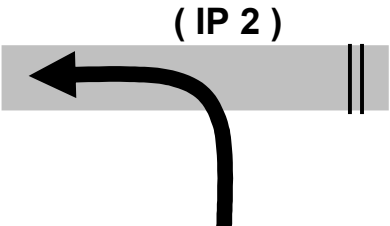
3	NERPOR - PROLOGUE	2,58 km
<p data-bbox="172 275 400 405">4,45</p> <p data-bbox="89 465 252 566">1,00</p>		<p data-bbox="1171 264 1401 309"><u>IP2 KM 177</u></p> <p data-bbox="1177 344 1410 427">TRIP CALIBRATION</p> <p data-bbox="1150 472 1437 510">MEDIDA PADRÃO</p> <p data-bbox="1401 510 1449 555">10</p>
<p data-bbox="177 633 395 763">6,20</p> <p data-bbox="89 824 252 925">1,75</p>		<p data-bbox="1139 629 1449 741">Q^TRO</p> <p data-bbox="1171 763 1422 808">(IP2 KM 178,8)</p> <p data-bbox="1401 869 1449 913">11</p>
<p data-bbox="177 992 395 1122">6,88</p> <p data-bbox="89 1182 252 1283">0,68</p>		<p data-bbox="1209 1070 1369 1115">START</p>  <p data-bbox="1401 1227 1449 1272">12</p>
<p data-bbox="177 1350 395 1480">7,03</p> <p data-bbox="89 1541 252 1641">0,15</p>		 <p data-bbox="1225 1608 1342 1641">CH/TC 1</p> <p data-bbox="1401 1585 1449 1630">13</p>

PAGE 1	SS1 / PORTALEGRE (NERPOR)		
1	0,00		TRIP A ZERO  CH/TC 1A
2	0,13		
3	1,15		
4	3,47		
5	3,62		

PROXIMA NOTA
PROCH.NOTE
NEXT NOTE

0,48

4,10

0,48

6

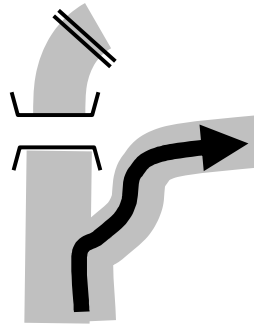

~~IP2~~
Portalegre

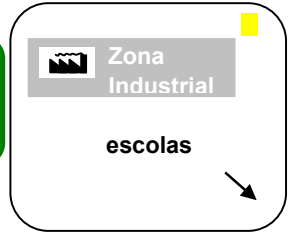

4,32

0,22

7

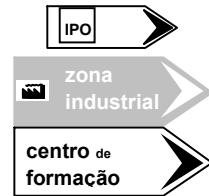
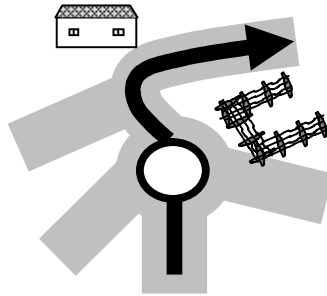

4,77

0,45

8

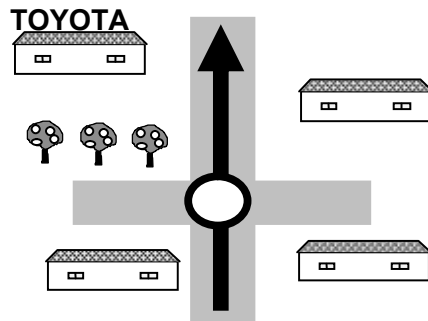

5,28

0,51

9

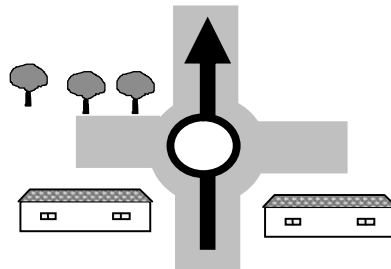

5,62

0,34

10

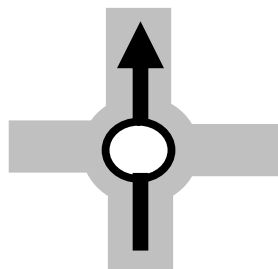

À ESQUERDA
ESTAÇÃO DE
LAVAGEM AUTO

ON THE LEFT CAR
WASH SELF SERVICE

5,87

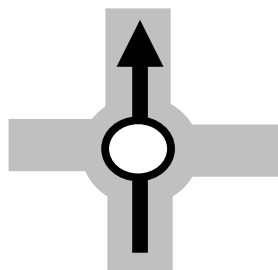

11

0,25

6,20

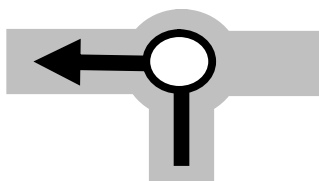

12

0,33

6,71

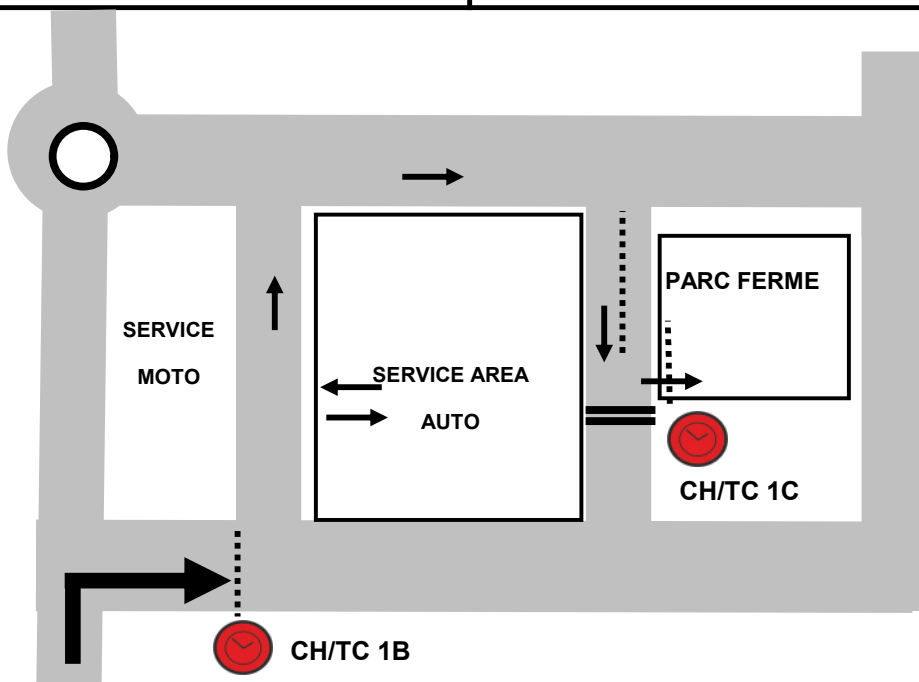



13

0,51

1	NERPOR - START SS2	38,92 km
<p>0,00</p> <p>0,00</p>		<p>1</p>
<p>0,54</p> <p>0,54</p>		<p>D 95</p> <p>2</p>
<p>0,87</p> <p>0,33 ↓</p>		<p>Castelo Branco Évora</p> <p>D 95 98</p> <p>3</p>
<p>1,08</p> <p>0,21</p>		<p>Castelo Branco Castelo de Vide A23</p> <p>4</p>

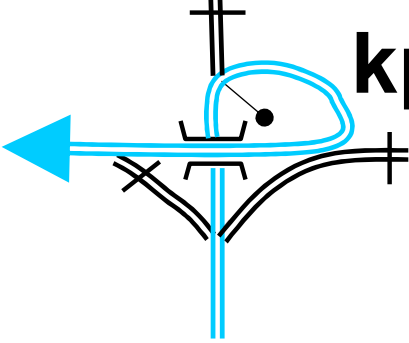
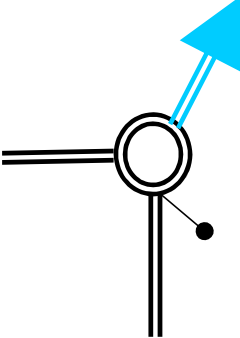
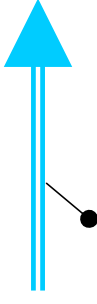

NEXT 2,29



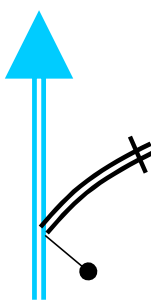
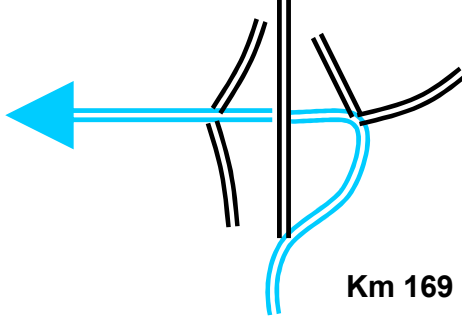
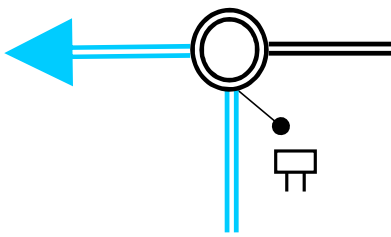
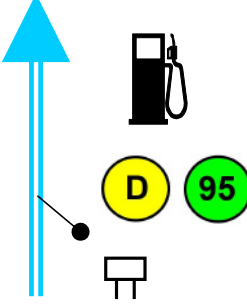
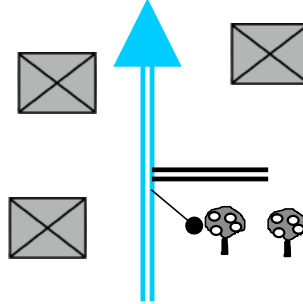
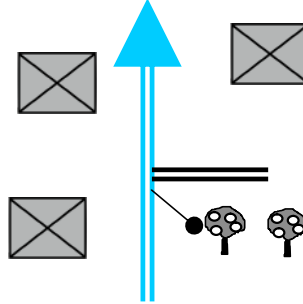

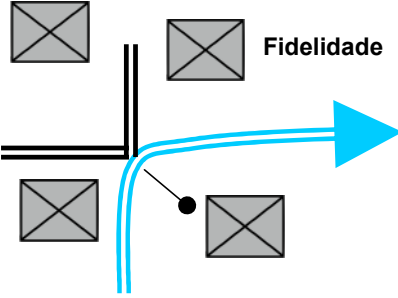
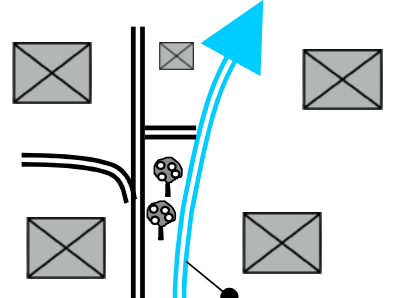
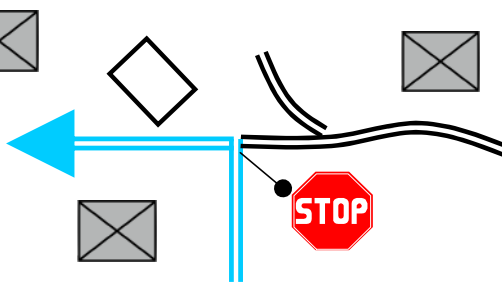
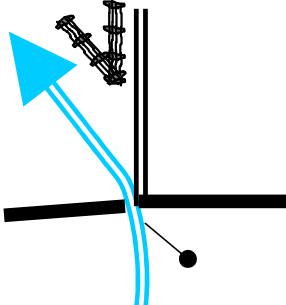
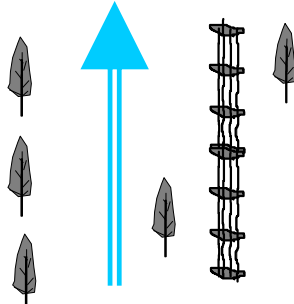

2	NERPOR - START SS2	35,55 km
3,37		<p>C.Branco C.Vide N118</p> <p>→</p> <p>↑ C.Vide Marvão</p> <p>5</p>
2,29		<p>↑ N18 C.Branco Nisa</p> <p>IC13 P.Spr Crato</p> <p>←</p> <p>6</p>
5,20		<p>FORTIOS</p> <p>7</p>
1,83		<p>↑ C.Branco Nisa A23</p> <p>Alagoa</p> <p>→</p> <p>8</p>
8,64		<p>Crato Alpalhão Nisa</p> <p>→</p> <p>9</p>
3,44		
7,12		
9,10		

NEXT 4,57

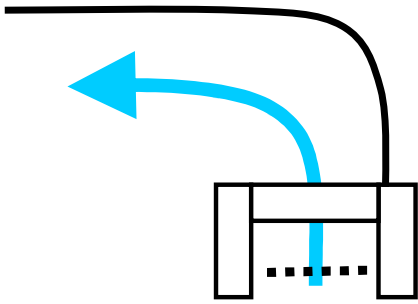

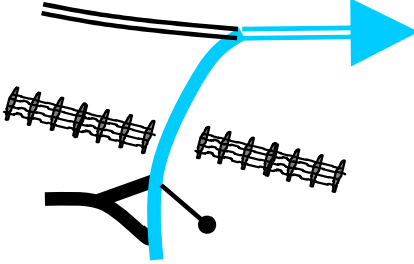
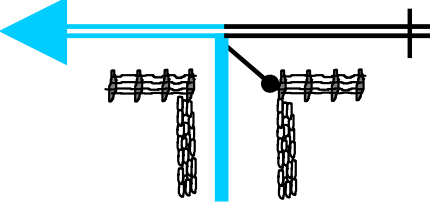

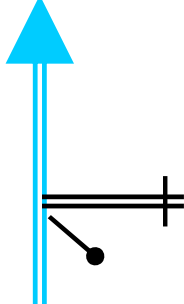
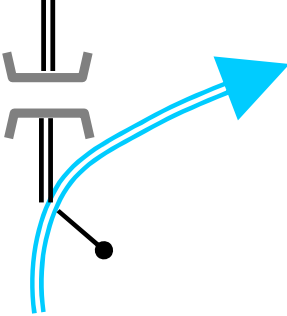
3	NERPOR - START SS2	9,49 km
29,43		<p>C.Branco A23 Abrantes</p> <p>Gafete</p> <div style="border: 1px solid black; padding: 2px; display: inline-block;">10</div>
4,57	 <p style="text-align: right;">Km 169 IP2</p>	<p>Tolosa</p> <p>C.Branco A23 Abrantes</p> <div style="border: 1px solid black; padding: 2px; display: inline-block;">11</div>
33,04		<p>Gafete</p> <p>Tolosa</p> <div style="border: 1px solid black; padding: 2px; display: inline-block;">12</div>
33,68		<p>Gafete</p> <div style="border: 1px solid black; padding: 2px; display: inline-block;">13</div>
35,38		<p>Mte da Pedra</p> <div style="border: 1px solid black; padding: 2px; display: inline-block;">14</div>
36,22		<p>Mte da Pedra</p> <div style="border: 1px solid black; padding: 2px; display: inline-block;">14</div>
0,64		
0,84		

NEXT 0,23

4	NERPOR - START SS2	2,50 km
36,45		
0,23 ↓		15
36,50		Crato Vale do Peso →
0,05 ↓		16
36,75		Crato Vale do Peso ←
0,25		17
38,56		Estação V. Peso ←
1,81		18
38,92		
0,36		CH/TC 2 19

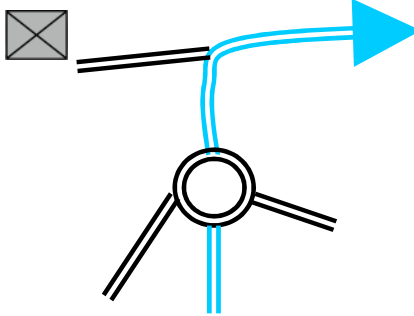
1	ARRIVAL SS2 - NERPOR	5,99 km
0,00		 CH/TC 2A 1
0,00		
1,20		RO 2
1,20		
1,80		 3
0,60		
2,72		4
0,92		
3,36		IP2 PORTALEGRE POLITECNICO ZONA INDUSTRIAL  5
0,64		

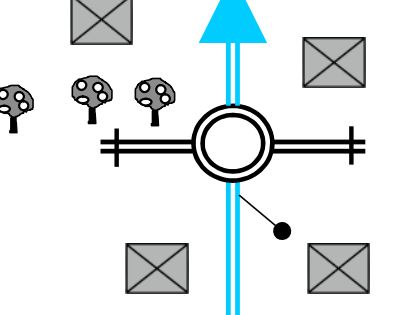
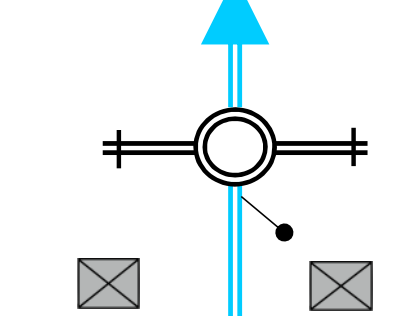
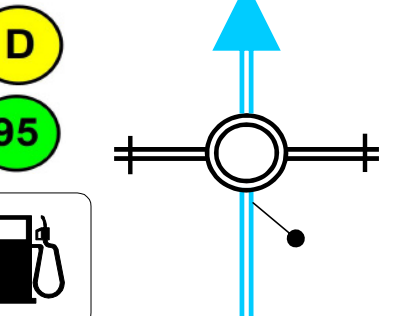
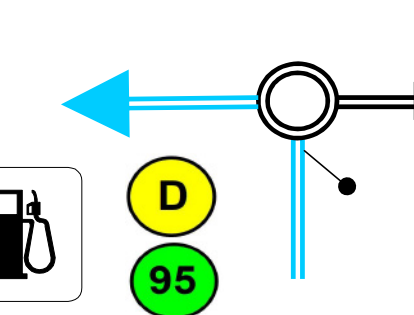
NEXT 0,16

2	ARRIVAL SS2 - NERPOR	2,47 km
<p style="background-color: #00FF00; color: black; padding: 10px; font-size: 24px; text-align: center;">3,52</p> <p style="background-color: #00FF00; color: black; padding: 5px; font-size: 18px; text-align: center;">0,16</p>		<p>ZONA INDUSTRIAL CENTRO INSPEÇÕES</p>  <div style="border: 1px solid black; width: 20px; height: 20px; text-align: center; line-height: 20px; margin-left: auto;">6</div>
<p style="font-size: 24px; text-align: center;">3,98</p> <p style="border: 1px solid black; padding: 5px; font-size: 18px; text-align: center;">0,46</p>		<div style="border: 1px solid black; width: 20px; height: 20px; text-align: center; line-height: 20px; margin-left: auto;">7</div>
<p style="font-size: 24px; text-align: center;">4,48</p> <p style="border: 1px solid black; padding: 5px; font-size: 18px; text-align: center;">0,50</p>		<div style="border: 1px solid black; width: 20px; height: 20px; text-align: center; line-height: 20px; margin-left: auto;">8</div>
<p style="font-size: 24px; text-align: center;">4,82</p> <p style="border: 1px solid black; padding: 5px; font-size: 18px; text-align: center;">0,34</p>		<p>À ESQUERDA ESTAÇÃO DE LAVAGEM AUTO</p> <p>ON THE LEFT CAR WASH SELF SERVICE</p> <div style="border: 1px solid black; width: 20px; height: 20px; text-align: center; line-height: 20px; margin-left: auto;">9</div>
<p style="font-size: 24px; text-align: center;">5,40</p> <p style="border: 1px solid black; padding: 5px; font-size: 18px; text-align: center;">0,58</p>		<p>ELVAS ARRONCHES C.po MAIOR ESPANHA</p>  <div style="border: 1px solid black; width: 20px; height: 20px; text-align: center; line-height: 20px; margin-left: auto;">11</div>

NEXT 0,59

3

ARRIVAL SS2 - NERPOR

0,59 km

5,99

0,59

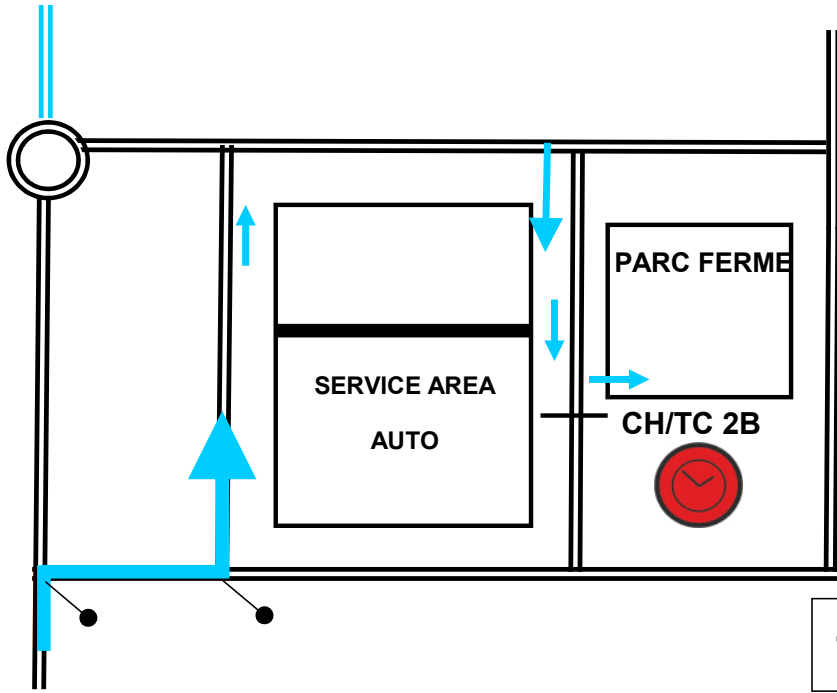

12

GAS 1 CONCAVADA - ABRANTES

N 39° 26.025' / W 8° 4.783'

37ª EDIÇÃO
BAJA PORTALEGRE 2023
AUTOMÓVEL CLUB DE PORTUGAL

500

SPARK
BAJA WORLD CUP

FIMR

GAS 1 CONCAVADA

28.10.2023

De / From
Gáfete / Portalegre

Para / To
GAS 2

- Percurso Assistências / Service car liaison
- Percurso Concorrentes / SS race
- Espaço de Assistência / Service area



600 m

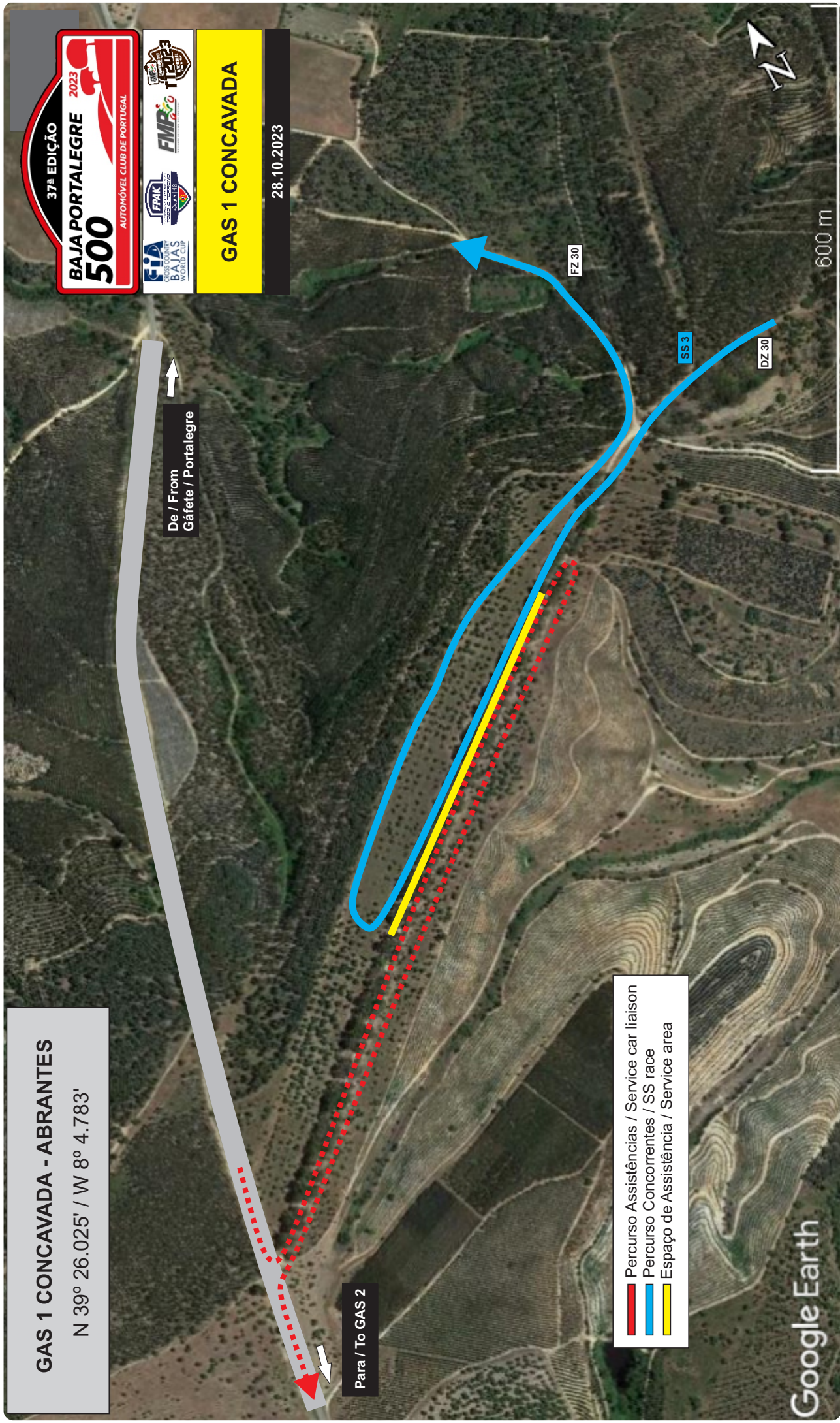

GAS 4 - TORRE DAS VARGENS

N 39° 18.492' / W 7° 54.948'

D2 30

SS 2 Promoção Baja & Hobby

FZ 30

N364

Torre das Vargens

De GAS 1
Molinho do Torrão / Sumo

Para final
Vale de Agor
Portalegre

500 m



- Percurso Assistências / Service car liaison
- Percurso Concorrentes / SS race
- Espaço de Assistência / Service area











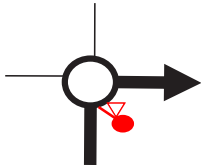

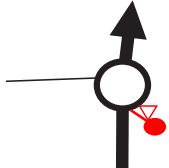

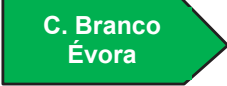
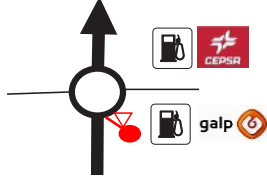

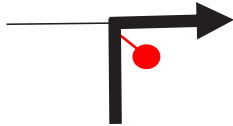

GAS 4 T. DAS VARGENS
Promoção Baja & Hobby

28.10.2023

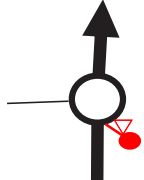

ASSISTÊNCIAS PROMOÇÃO BAJA E HOBBY (SS2)

Total Kms 187,41

Distance		Direction	Information
Total	Partial		
NERPOR - START SS 2			
0,00	0,00	 NERPOR	
0,53	0,53		 
0,86	0,33		  
1,11	0,25		  
3,26	2,15		
3,40	0,14		 
5,19	1,79		

ASSISTÊNCIAS PROMOÇÃO BAJA E HOBBY (SS2)

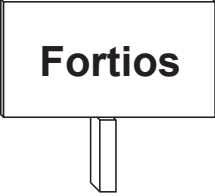
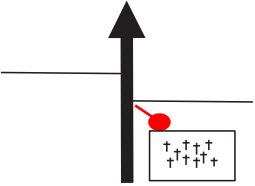
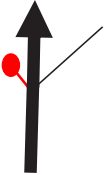
Total Kms 187,41

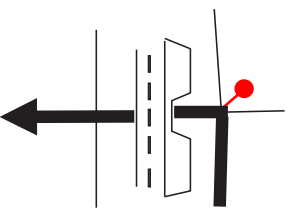
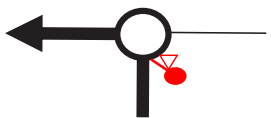
	Distance		Direction	Information
	Total	Partial		
8	8,55	3,36		
9	15,70	7,15		Alagoa Flor da Rosa
10	24,71	9,01		Crato Alpalhão C. Vide Nisa
11	29,28	4,57		Gafete
12	32,89	3,61		Tolosa
13	33,00	0,11		Tolosa
14	33,47	0,47		Gafete

ASSISTÊNCIAS PROMOÇÃO BAJA E HOBBY (SS2)



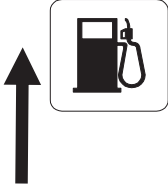







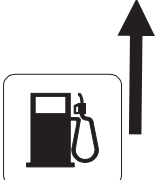
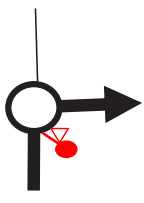

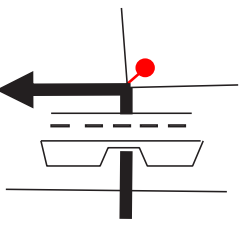

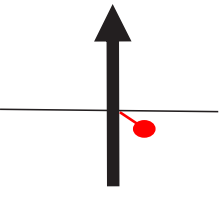
Total Kms 187,41

Distance		Direction	Information
Total	Partial		
35,10	1,63		PARTIDA DE GAFETE (A ASSISTÊNCIA É PERMITIDA APENAS ATÉ ESTE LOCAL)

15



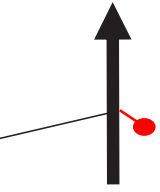



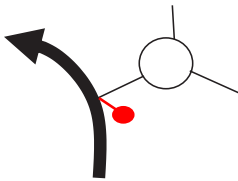

ASSISTÊNCIAS PROMOÇÃO BAJA E HOBBY (SS2)

Total Kms 187,41

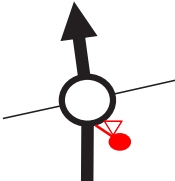
	Distance		Direction	Information
	Total	Partial		
START SS 2 - GAS 1 (CONCAVADA)				
16	0,00	0,00		Retome o percurso em sentido inverso
17	1,65	1,65		
18	2,12	0,47		
19	4,63	2,51		 
20	8,69	4,06		  
21	8,98	0,29		
22	24,66	15,68		 

ASSISTÊNCIAS PROMOÇÃO BAJA E HOBBY (SS2)

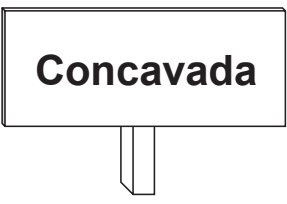
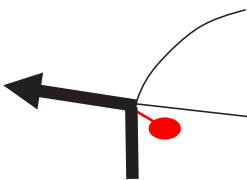

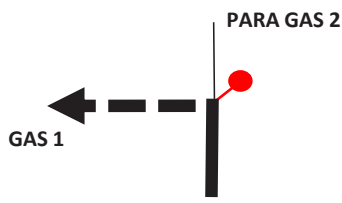
Total Kms 187,41

	Distance		Direction	Information
	Total	Partial		
23	26,98	2,32		
24	38,59	11,61		  
25	40,02	1,43		
26	41,00	0,98	 Concavada	 
27	42,80	1,80		GAS 1 Concavada

Distance		Direction	Information
Total	Partial		
GAS 1 (CONCAVADA) - GAS 4 (TORRE DAS VARGENS)			
0,00	0,00		Retome o percurso em sentido inverso
1,80	1,80		
4,14	2,34		
15,77	11,63		
18,08	2,31		
20,01	1,93		
30,97	10,96		

ASSISTÊNCIAS PROMOÇÃO BAJA E HOBBY (SS2)

Total Kms 187,41

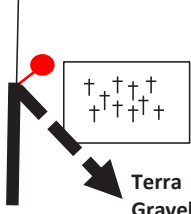
	Distance		Direction	Information
	Total	Partial		
35	36,00	5,03	 <p>Torre das Vargens</p>	
36	36,62	0,62	 <p>Torre das Vargens</p>	
37	37,60	0,98	 <p>Terra Gravel</p>	<p>GAS 4 Torre das Vargens</p>

ASSISTÊNCIAS PROMOÇÃO BAJA E HOBBY (SS2)

Total Kms 187,41

	Distance		Direction	Information
	Total	Partial		
GAS 4 (TORRE DAS VARGENS) - STOP SS 2				
38	0,00	0,00	Asfalto Asphalt 	Retome o percurso no mesmo sentido
39	6,54	6,54	Vale de Açor 	
40	23,11	16,57		
41	28,24	5,13		
42	55,84	27,60		
43	56,86	1,02		
44	58,36	1,50		

ASSISTÊNCIAS PROMOÇÃO BAJA E HOBBY (SS2)

Total Kms 187,41

	Distance		Direction	Information
	Total	Partial		
45	60,62	2,26		Elyas Arronches ESPANHA Portalegre
46	61,79	1,17		zona industrial politécnico centro inspeções
47	64,96	3,17		(Terra / Gravel)
48	65,65	0,69		FINAL Terra Gravel

ASSISTÊNCIAS PROMOÇÃO BAJA E HOBBY (SS2)

Total Kms 187,41

Distance		Direction	Information
Total	Partial		
STOP SS 2 - NERPOR			
49	0,00		FINAL
50	0,67		
51	1,07		
52	1,38		(Asfalto / Asphalt Road)
53	2,92		
54	3,47		
55	3,63		

ASSISTÊNCIAS PROMOÇÃO BAJA E HOBBY (SS2)

Total Kms 187,41

	Distance		Direction	Information
	Total	Partial		
56	4,59	0,96		
57	4,93	0,34		
58	5,18	0,25		
59	5,51	0,33		<div style="border: 1px solid black; padding: 5px; display: inline-block; margin-bottom: 10px;">Elvas Arronches</div> <div style="border: 1px solid black; padding: 5px; display: inline-block;">Portalegre</div>
60	6,26	0,75		NERPOR

Segurança dos Espectadores

Spectator Safety

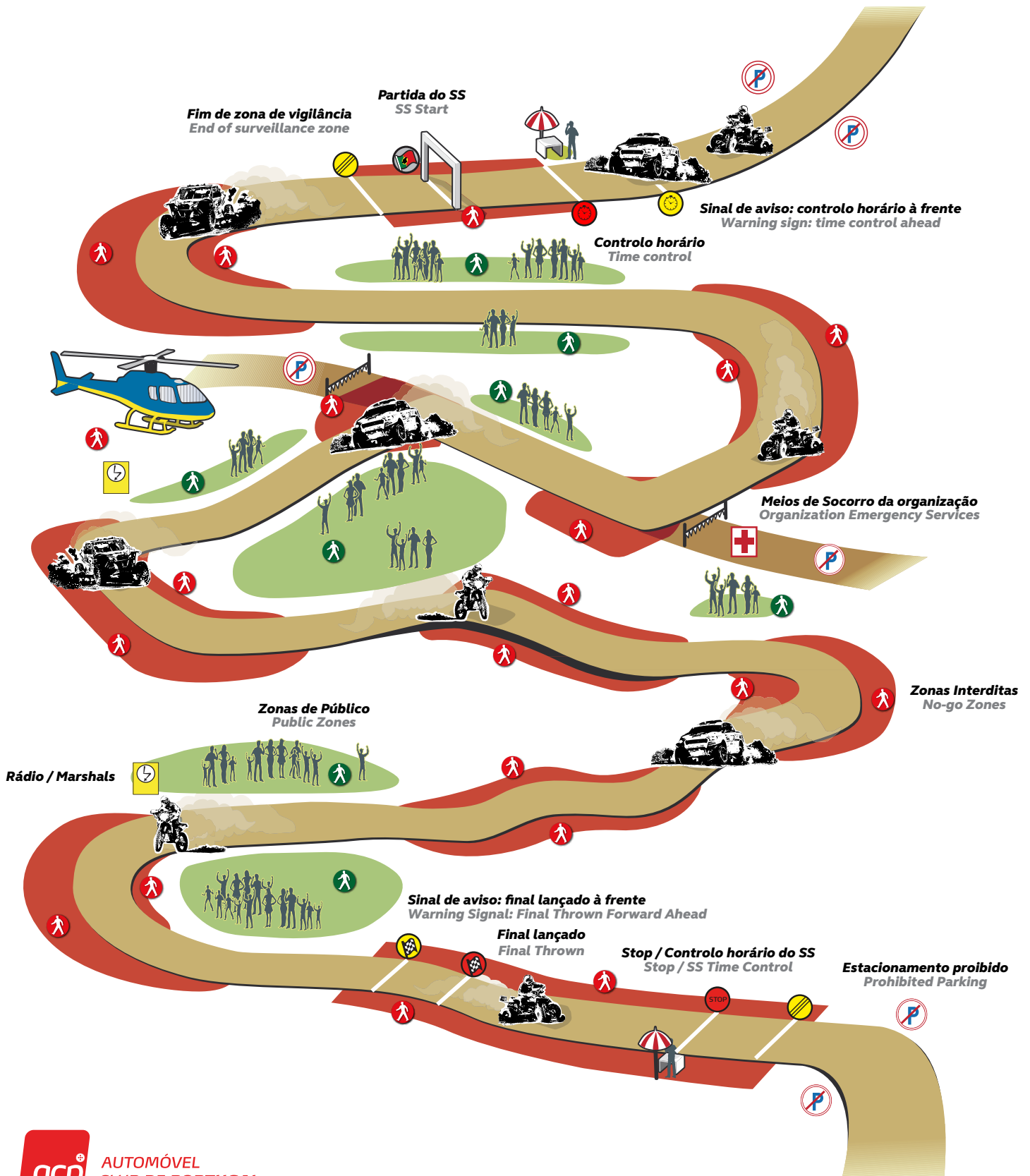

bp
ultimate
com tecnologia
ACTIVE

